

FLEXIBLE PVC SWING DOOR

SIMPLE DOUBLE-ACTION DOOR TO IMPROVE THE THERMAL AND ACOUSTIC INSULATION OF YOUR PREMISES

INDUSTRY/LOGISTICS



FLEXIBLE PVC
SWING DOOR

SP2000

A DOOR DESIGNED TO LAST!

- Much **cheaper** to buy and maintain than a high-speed door, the **SP2000** flexible PVC swing door **requires no maintenance or even periodic checking**.
- It features an **extremely rugged metal structure** and double-acting operation thanks to an **integrated, impact-protected return system**, for sizes up to 8 m x 8 m.
- There is no risk of this door **breaking down** and leaving staff and goods stranded on one side.



FEATURES & BENEFITS



Reduces heat loss



Heavy-duty product



Superior quality



Wide enough for forklift trucks



Economical



Recyclable



- It allows you to **keep heat loss or cold air leakage to a minimum** since the opening of the door is always limited to the size of the person or vehicle going through it and the leaves close automatically immediately afterwards
- It allows the **passage of suspension rails** and **overhead cranes**.
- **Made to measure and supplied ready to fit**, it is available in **manual and automatic versions**, single or double-leaf, to meet all your requirements.

TECHNICAL CHARACTERISTICS

STRUCTURE

- Heavy duty **coated steel** structure,
- Return system adjustable with a **torsion spring integrated into the frame** and protected from impacts
- Rotates on a **height-adjustable pivot**,
- **Anti-drop device** on large doors,
- Optional **90° hold open feature**,
- Opening simply by pushing and automatic closing by an **adjustable tension system**.

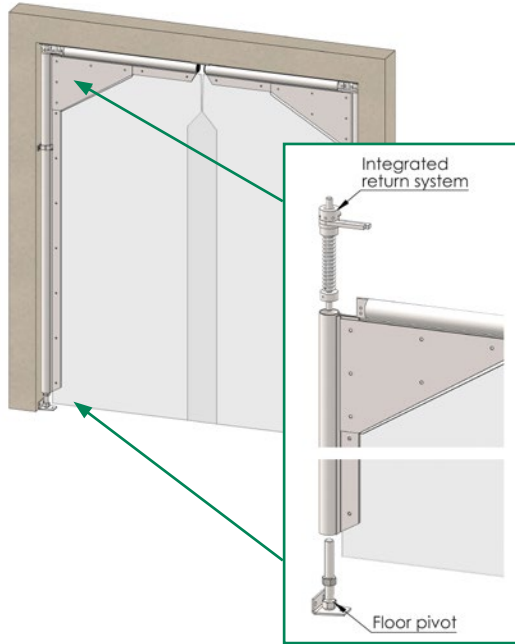

STRUCTURE COLOUR



FLEXIBLE PVC PANELS

- Overlapping in the centre for double-leaf doors,
- 6 or 8 mm thick,
- Transparent crystal flexible PVC with possibility of having opaque flexible PVC for impact sections at the top and/or bottom.

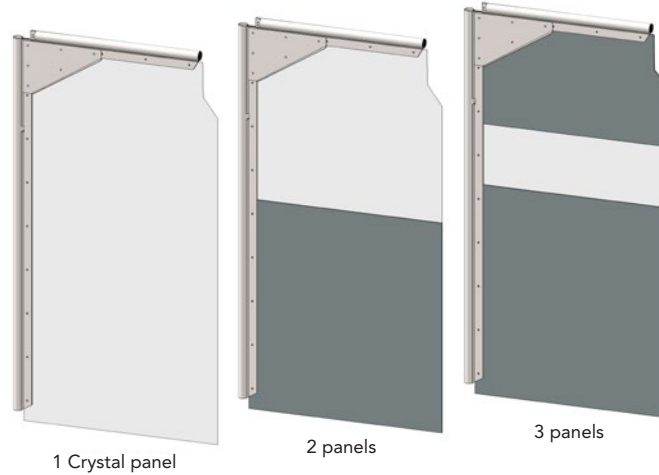

COLOURS OF OPAQUE FLEXIBLE PVC

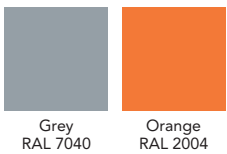

OPTIONS

- 90° hold open feature,
- Single-acting operation – the leaves will open in one direction only,
- All grade 304L brushed stainless steel version (structure, return mechanism, pivots, etc.) for aggressive or food industry environments,
- Automatic version with electro-pneumatic mechanism.

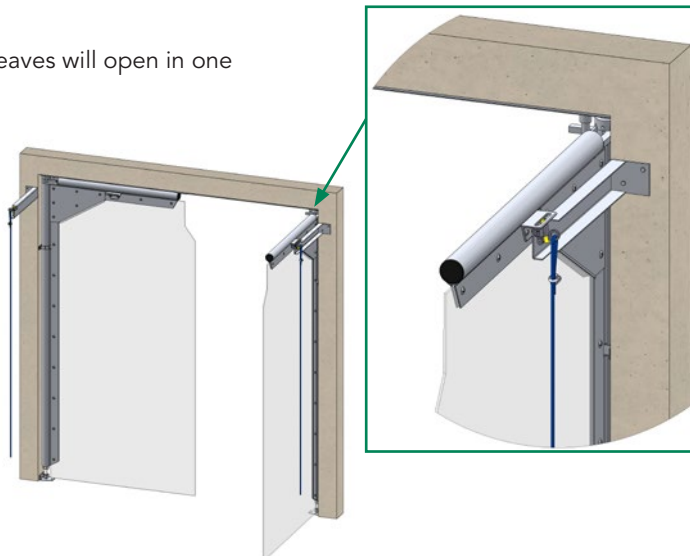

FLEXIBLE PVC SWING DOOR

SP2000

